



 Precast/Prestressed
Concrete Institute
MEMBER

**SERVICE MANUAL
FOR YOUR
PSI HERCULES
MODEL C
STRAND JACK**

**PLEASE READ MANUAL
CAREFULLY
BEFORE OPERATING**

PRESTRESS SUPPLY INC.

**PHONE (863) 683-4492
OR (863) 683-4111
TOLL FREE 1-800-328-8036**

TABLE OF CONTENTS

Statement of Warranty.....	(1)
Warranty Claims	(2)
Serial Number Location	(2)
Ordering Parts	(2)
Assembly Instruction	(3)
Amperage Requirements.....	(3)
General Instructions	(3)
Controls/Calibration	(4-10)
Maintenance	(11)
Hydraulic Oil	(11)
Part #'s and Photos	(12-17, 20-21)
Rebuilding Cylinder	(18-19)
Questions & Troubleshooting	(22-24)

THIS PAGE INTENTIONALLY LEFT BLANK

Prestress Equipment Fabrication, LLC
WARRANTY

WARRANTY

PEF will repair or replace any portion of the equipment which proves to be defective within a period of 3 months from the date of shipment upon the return of same to PEF at purchaser's expense when such defects are due to defective materials supplied by PEF or defective workmanship of its employees, provided that the equipment shall have been properly installed, maintained and utilized during the period covered by this warranty, and provided further that this warranty shall extend only to the purchaser and no other party by any means, and provided, finally that PEF shall in no event be responsible for the cost of field labor, calibration or other charges incurred by the purchaser. At all times, PEF shall have and possess the sole right and option to determine whether to repair or replace defective equipment. Machinery parts, accessories and components manufactured by others are warranted only to the extent of the original manufacturer's warranty.

EXCLUSION OF OTHER WARRANTIES

EXCEPT FOR THE ABOVE EXPRESS WARRANTY, THERE ARE NO WARRANTIES, INCLUDING ANY IMPLIED WARRANTIES OF MERCHANTABILITY OR FITNESS FOR ANY PARTICULAR PURPOSE, WHICH EXTEND BEYOND THE DESCRIPTION OF THE EQUIPMENT ON THE FACE HEREOF. NO WARRANTIES OR REPRESENTATIONS AT ANY TIME MADE BY ANY SALES REPRESENTATIVE OF PEF SHALL BE EFFECTIVE TO VARY OR EXPAND THE FOREGOING EXPRESS WARRANTY OR ANY OTHER TERMS HEREOF.

WARRANTY CLAIMS

Proper presentation of warranty claims will expedite the claim handling. The procedure is simple and outlined below:

- (A) Notify PRESTRESS SUPPLY INC. of any malfunction or failure of PEF equipment.
- (B) Provide detailed information about the problem encountered.
- (C) Have serial number and model number of the equipment.
- (D) Return damaged or defective parts to PEF in a timely manner for warranty consideration.

SERIAL NUMBER LOCATION

Serial numbers are located on the cylinder head body and stanchion flange of ram. Also on the inside of the pump unit cabinet near the pump and motor.

ORDERING PARTS

Replacement parts for your PEF equipment should be ordered from PRESTRESS SUPPLY INC. Some standard hardware parts may be found locally.

When ordering parts PLEASE have your model and serial number available. You may look at the descriptive photos and drawings to identify the parts needed. If you are not sure about the part you may need, contact PRESTRESS SUPPLY INC. for help.

ASSEMBLY INSTRUCTIONS

- (1) Slide the stanchion over the chuckbox and up to the cylinder head. Line up all the mounting holes and install the supplied mounting bolts. The bolts should be tightened in a star pattern using 110-113 foot/pounds of torque.
- (2) Connect the pull & return hoses to the ram. Make sure all hose fittings and connections are free of dirt and debris.
- (3) Mount horn & light pole to pump unit using supplied hardware.
WARNING: Do not install quick disconnect fittings on your hydraulic hoses. These fittings will cause hydraulic flow problems and will make it easier to contaminate the hydraulic system.
DO NOT USE THEM!
- (4) Install the correct electrical plug for your plant (not included).
MAKE SURE THE VOLTAGE IS CORRECT!
- (5) Turn the system on and check the electric motor rotation. Model B should be counter clockwise, and Model C clockwise. If turning the wrong way, change the polarity at the plug.
- (6) Check hydraulic fluid level in tank.
- (7) With the system running, extend the ram all the way out and all the way back in several times to bleed any air out of the system.
- (8) Read the operating instructions in this manual.
- (9) Mount the ram on an adjustable hoist or gantry so the ram can be adjusted both vertically and horizontally. **THE RAM MUST BE IN ALIGNMENT WITH THE STRAND (CABLE) DURING STRESSING.**

AMPERAGE REQUIREMENTS

<i>Model B</i>	<i>Model C</i>
240V - 25 amps	240V - 48 amps
480V - 12.5 amps	480V - 24 amps

GENERAL INSTRUCTIONS

- (1) Do **NOT** allow anyone to operate this machine until they have read and understand the instructions. The operator should practice operating the pressure regulators without any cable in the ram. This can be done by pulling ram all the way back until the chuckbox bottoms out and stops. Now full pressure can be exerted on the ram with no damage. The operator should practice moving the ram, and setting the regulators until they feel confident in the operation.

- (2) The stressing system is **NOT** calibrated at the factory. You must first have the unit calibrated before attempting to stress cable. Attempting to stress without calibration could lead to a cable overload, resulting in **INJURY OR DEATH!**

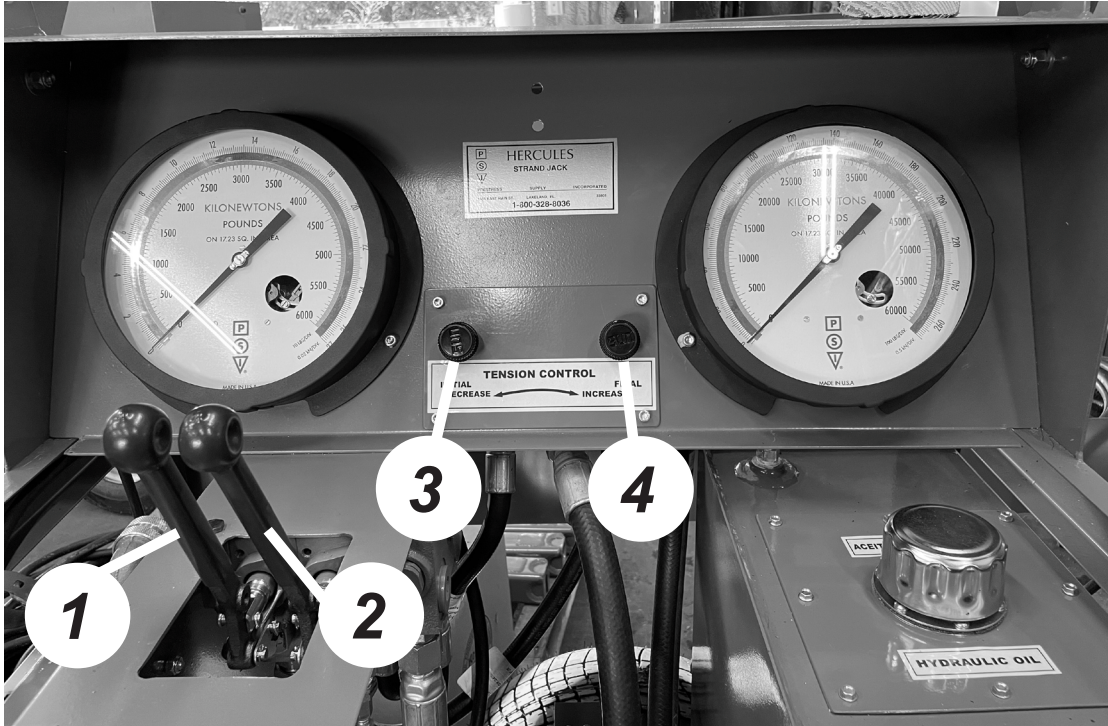

CONTROLS

- (1) **DIRECTIONAL CONTROL HANDLE**
The left handle on the control panel determines the direction of the ram movement. Pulling on the handle will move the chuckbox inward putting tension on the cable. Pushing the handle into the return mode will move the chuckbox back outward releasing the tension on the cable. **NOTE:** The chuckbox will not return unless the Initial-Final-Ease-Off handle (2) is in the Final Mode.
- (2) **INITIAL-FINAL-EASE-OFF HANDLE**
The right handle selects the Initial mode, Final mode, and the Ease-Off function. Using the Ease-Off function will gently release the hydraulic pressure allowing the chuck jaws to seat evenly and slowly.

WARNING: Attempting to release the cable without using the Ease-Off function will shock load the cable and strand chucks. Shock loading can damage your chuck jaws, slam your gauges out of calibration and could damage the cable, possibly resulting in cable failure.

(3) **INITIAL PRESSURE REGULATOR**

The left round knob on the control panel is the Initial Pressure control. This controls the amount of initial tension pressure when the Initial-Final handle is in the initial mode.

(4) **FINAL PRESSURE REGULATOR**

The right round knob on the control panel is the Final Pressure control. This controls the amount of final tension pressure when the Initial-Final handle is in the final mode.

NOTE: The final regulator knob must be opened at least 2-1/2 turns before the initial regulator will function.

PRESSURE INDICATION GAUGES

The Hercules jack comes with the option of analog or digital gauges. The analog system uses two gauges, one for initial readings and one for final readings. The digital system uses one gauge that indicates both initial and final readings.

CONTROL OF HYDRAULIC FLOW

All flow and regulation of hydraulic oil is controlled by the:

Main Manifold
Main Valve Manifold
Gauge Block Manifold

Valve cartridges located in the manifolds manage the flow of oil according to which lever the operator pushes or pulls.

The cartridge system was designed so if a problem develops, a cartridge valve can be easily removed and replaced.

NOTE: Cleanliness is of the utmost importance when servicing this unit, as most of the valves and manifolds have very small orifices which can be blocked by debris in the system. **CAUTION** should also be taken when replacing hoses and lines to make sure they are free of dirt or particles which could interrupt the flow.

The Initial and Final Pressure Regulator controls are pressure bypass valves that allow the tension pressure to be set so the ram will stop when the preset tension is reached. Operational pressure should be set at the beginning of the day and verified periodically throughout the day.

SETTING PRESSURE REGULATORS

Before placing the cable in the ram:

- (1) Set the Initial-Final handle to final.
- (2) Pull the directional control handle to move the chuckbox back until it bottoms out at the rear of the stanchion.
- (3) While holding the directional control handle in “pull”, slowly dial the Final Regulator clockwise until the gauge reaches your final target load.
- (4) Ease the pressure off using the Ease-Off function until the chuckbox moves.
- (5) Now pull again without touching the regulator control knob. Make sure the pressure comes back to the same desired target load. If it does not, repeat steps 1 through 4.

NOTE: While setting the pressure, if you go higher than your target load you **CANNOT** reduce the pressure back down. You must first drop the pressure using step 4 and turn the regulator knob back down and repeat step 3.

- (6) To set the initial pressure, move the selector handle to initial. While pulling the directional control handle, slowly dial the Initial Regulator knob clockwise until the gauge reaches your initial target load.
- (7) Release the initial pressure and without touching the Initial Regulator, pull the directional control handle again and watch the pressure come back up. If it does not stop at the same desired load, repeat step 6.
NOTE: for best results the initial pressure should be set to at least 3000 pounds of force.

JOGGING DIRECTIONAL CONTROLS

The system is designed to temporarily “hold” the target pressure needed. Once the ram and gauge have stopped moving, jogging the control valve will **NOT** help increase the ram pressure. However, jogging the valves will create pressure surges in the system and will cause inaccurate readings on the gauges.

DO NOT JOG THE CONTROL HANDLES

TENSIONING CABLE

After the cables (strand) have been positioned in the form and the strand chucks are in place on the cable, slide a strand chuck onto the strand being pulled, leaving enough room to be able to insert the “pulling” chuck into the chuckbox. Now an initial load can be placed on the cable.

Reference marks should be established from which elongation measurements can be made. Elongation measurements should take into account operational losses and chuck seating.

YOUR RAM SHOULD BE SET PARALLEL WITH THE STRAND DURING TENSIONING. THE RAM SHOULD NOT MOVE UP AND DOWN OR SIDE TO SIDE WHEN THE LOAD IS APPLIED!

INITIAL TENSION

- (1) Set initial and final regulator controls to your desired target loads outlined on page 6.
- (2) Set selector control to “initial”.
- (3) Pull directional control smoothly (do not yank or jog) the handle until the gauge stops at the desired load. Mark the cable for elongation measurements.

FINAL TENSION

- (1) Set selector control to “final”.
- (2) Pull and hold directional control handle until the gauge stops at the target load.
- (3) Mark, measure and record elongation measurements.

CAUTION: THE OPERATOR SHOULD ALWAYS NOTE THE TENSION AND ELONGATION TO MAKE SURE NEITHER ARE EXCEEDED DURING TENSIONING.

RETURNING THE RAM

Once your final load has been achieved and measurements taken, you can now return the chuckbox to release the pulling chuck and cable. Use the ease-off function to start the pressure drop. Once the gauge pressure has dropped 3000 pounds the chuck holding the cable has now fully seated and is holding the strand. Now switch to the return setting and finish returning the chuckbox to its starting position.

CAUTION: THE EASE-OFF FUNCTION MUST ALWAYS BE USED WHEN RELEASING FINAL TENSION ON THE CABLE. USING THE RETURN WITHOUT THE EASE-OFF WILL SHOCK LOAD THE SYSTEM, DAMAGING YOUR CABLE, CHUCKS AND GAUGES.

GAUGE CALIBRATION

Why calibrate the gauges? It's not to check the gauges, but to measure the friction loss in the hydraulic system and ram. This is why re-calibration is necessary after replacing a part or rebuilding a ram.

GAUGE PRESSURE RELATIONSHIP

The PSI Hercules jack is composed of two separate systems, inter-related, but separate. They are:

- (1) The gauge system
 - (2) Pressure control system
-
- (A) The gauges measure how much oil pressure is introduced into the jacking circuit, nothing else.
 - (B) The pressure control system governs the oil pressure in the jack circuit. The regulators on the panel tell the system what pressure to hold at.

There are several factors that can cause the regulators to drift off. The most common is a change in oil temperature. Lack of repeatability or drift should not be confused with gauge inaccuracy! They are not related.

CALIBRATION PROCEDURES

The gauges, cylinders and power unit **MUST** be calibrated as a system in the same manner that the unit will be used for tensioning operations. The calibration points should be in 5000 pound increments up to the maximum allowable load for the size cable being used.

Calibrations should be performed by an approved testing lab, calibration service, or under the supervision of a professional engineer. Re-calibration should be performed any time the system is indicating erratic results, replacing a hydraulic component, changing rams, or 12 months has been exceeded.

The calibrator should use a certified loadcell system to record the actual pressure loading on the strand. The loadcell must be in calibration with certification documents to support this.

NEVER ATTEMPT TO CALIBRATE A STRESSING SYSTEM WITH AN OUT OF DATE LOADCELL.

CAUTION: DO NOT ALLOW FINAL TENSION TO BE EXCEEDED FOR THE SIZE STRAND BEING USED IN THE CALIBRATION.

ADJUSTING GAUGE SNUBBERS

ANALOG GAUGES ONLY

Snubbers are attached to the back of the gauges and are connected to the hydraulic line.

The analog gauges are protected from rapid pressure changes and surges by the use of gauge snubbers. If the snubber is incorrectly set, the gauge can be damaged.

If the gauge needle moves too slowly or the gauge will not move at all, the gauge snubber may need to be opened.

If the gauge needle is acting erratically and is jumping around, the snubber may need to be closed a little.

*Adjustments to the snubber should be done in **VERY** small increments, then tested.*

To fine tune the snubber, slowly adjust the knob clockwise to close the flow and counter-clockwise to open the flow.

JACK MAINTENANCE

The hydraulic pump is protected by an in-tank strainer. The strainer should be inspected and cleaned when the hydraulic oil is changed. Changing the hydraulic oil and cleaning the tank should be done annually. With heavy use the oil should be changed twice a year. The rest of the hydraulic system is protected by a high pressure filter. The filter element is located inside the high pressure filter housing, and should be changed quarterly. Grease fittings on the motor and fan should be greased every 50 hours.

DO NOT OVER GREASE

HYDRAULIC OIL

Use any good quality petroleum based hydraulic oil, light turbine oil, dextron, or A. T. F.

DO NOT USE ANY TYPE OF HEAVY OIL

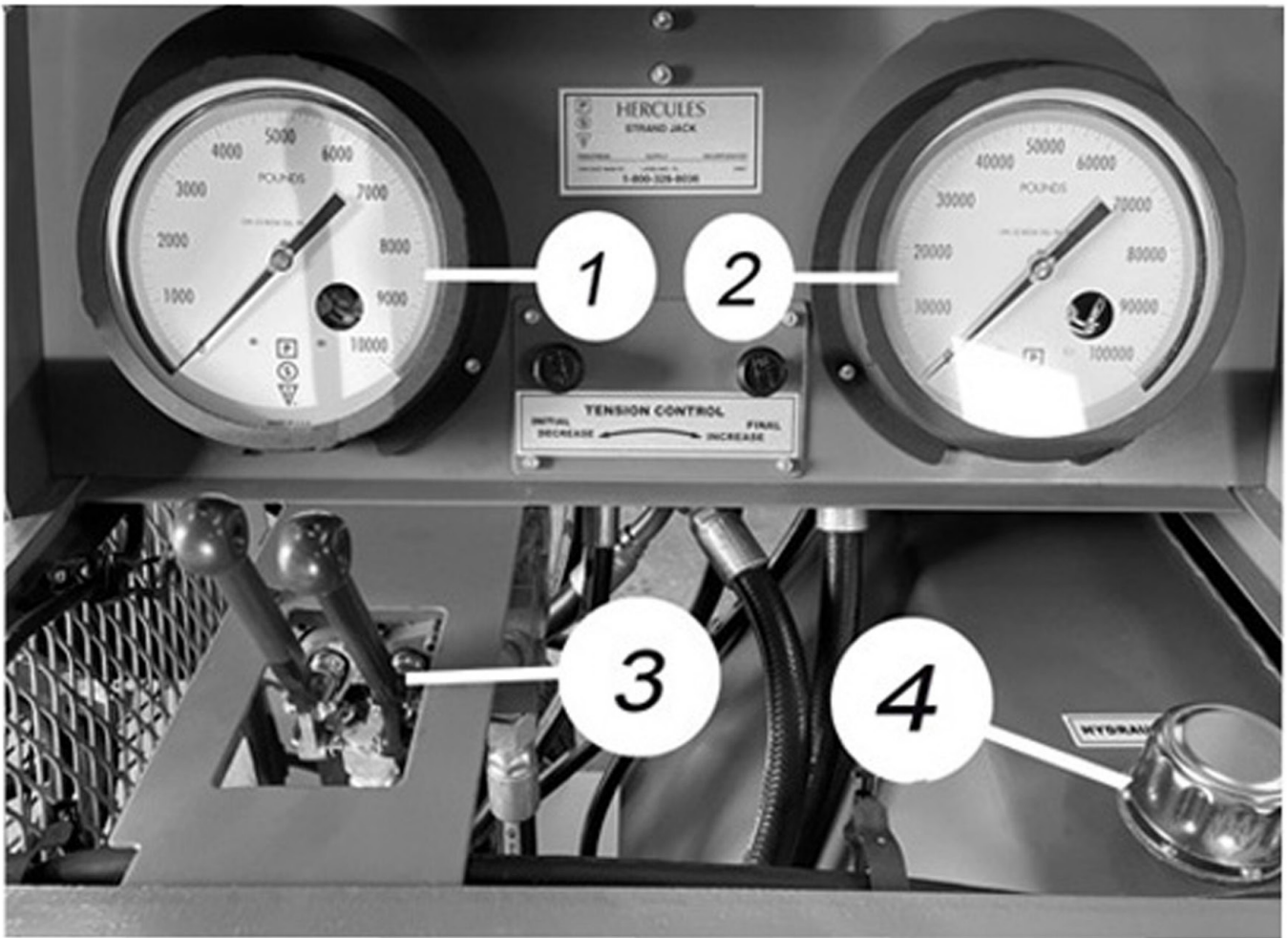

KEY

PART#

DESCRIPTION

01

C8045

Initial Gauge

02

C8046

Final Gauge

03

61430

Main Control Valve

04

61181

Reservoir Filler Cap

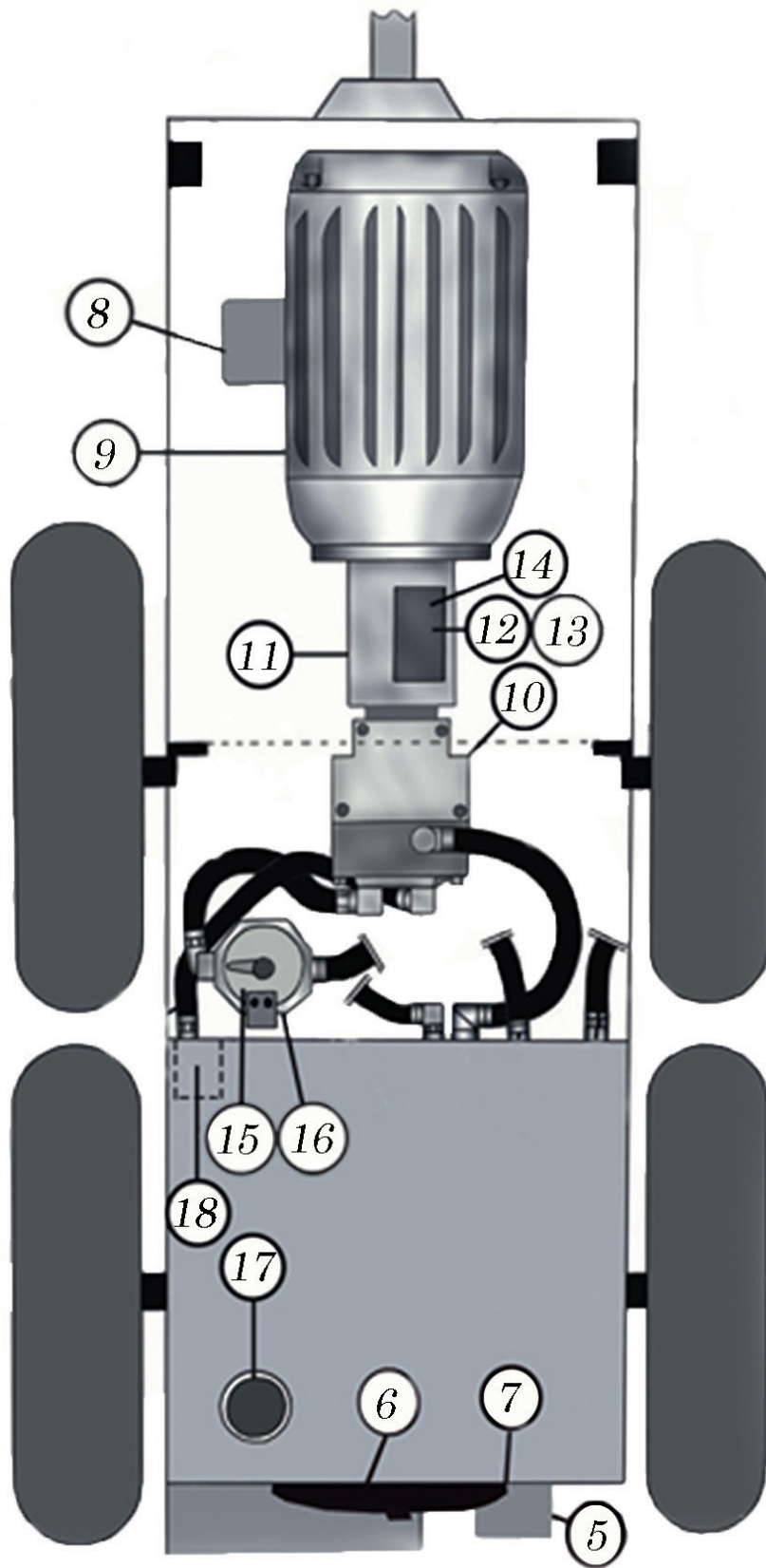

KEY	PART#	DESCRIPTION
06	C8090	Reservoir Cover with Gasket
07	C8090-01	Cover Gasket
08	C8008	Motor Wiring Doghouse
09	C8009	Electric Motor
10	C8010	Hydraulic Pump
11	C8011	Coupling Housing & Mount
12	C8012	Coupling A (motor side)
13	C8013	Coupling B (pump side)
14	C8014	Coupling Insert
15	C8015	High Pressure Filter Housing
16	C8016	Filter Element
17	C8017	Reservoir Filler Cap
18	C8018	In Tank Strainer

PARTS NOT SHOWN

KEY	PART#	DESCRIPTION
19	60140	Transformer
20	C8019	Gauge Snubber
21	C8034	Horn & Light Kit
22	C8035	Replacement Horn
23	C8036	Replacement Light
24	C8037	Replacement Strobe Bulb
25	C8038	Horn Button
26	C8039	On Power Button
27	C8040	Off Power Button

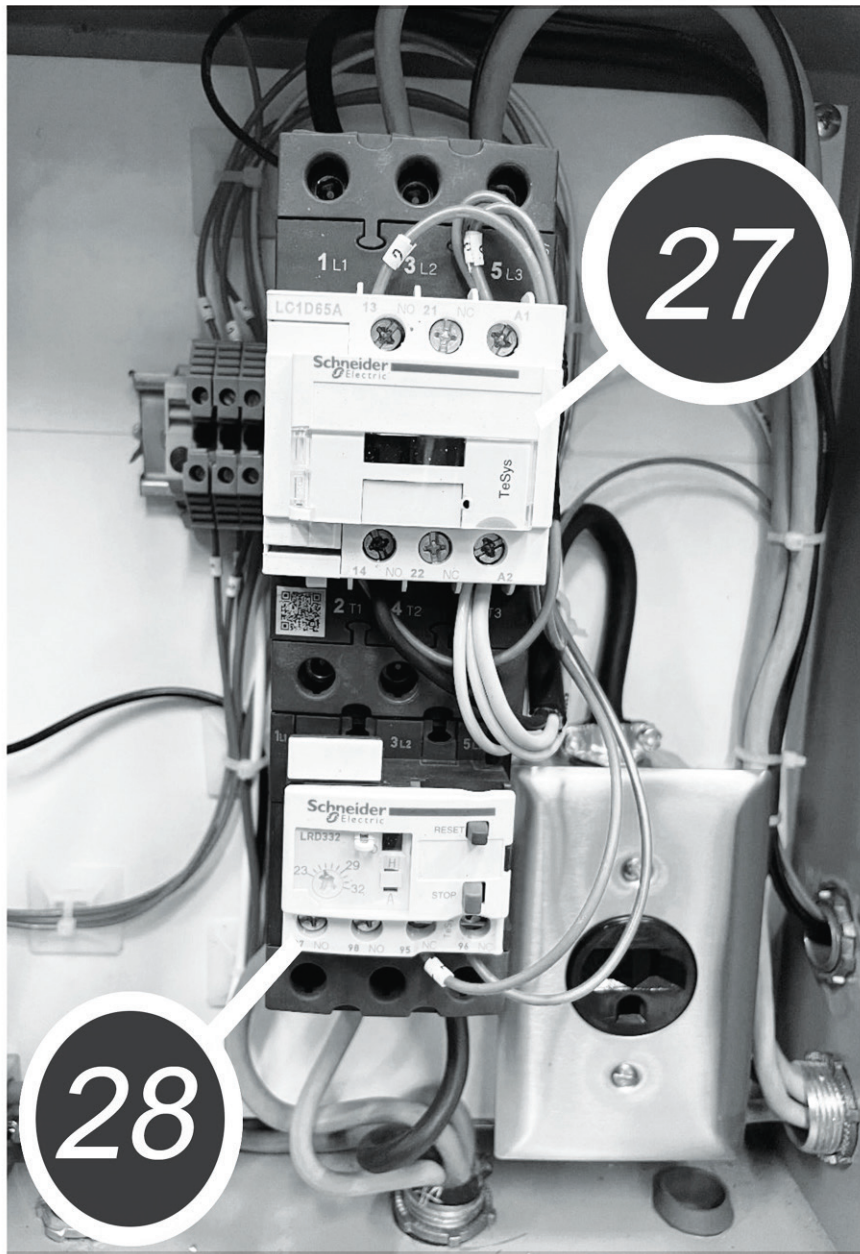

MODEL C ELECTRICAL BOX

KEY	PART#	DESCRIPTION
27	LC1D-65A	AC Coil
28	LRD332	Overload (440V)
28	LRD365	Overload (220V)

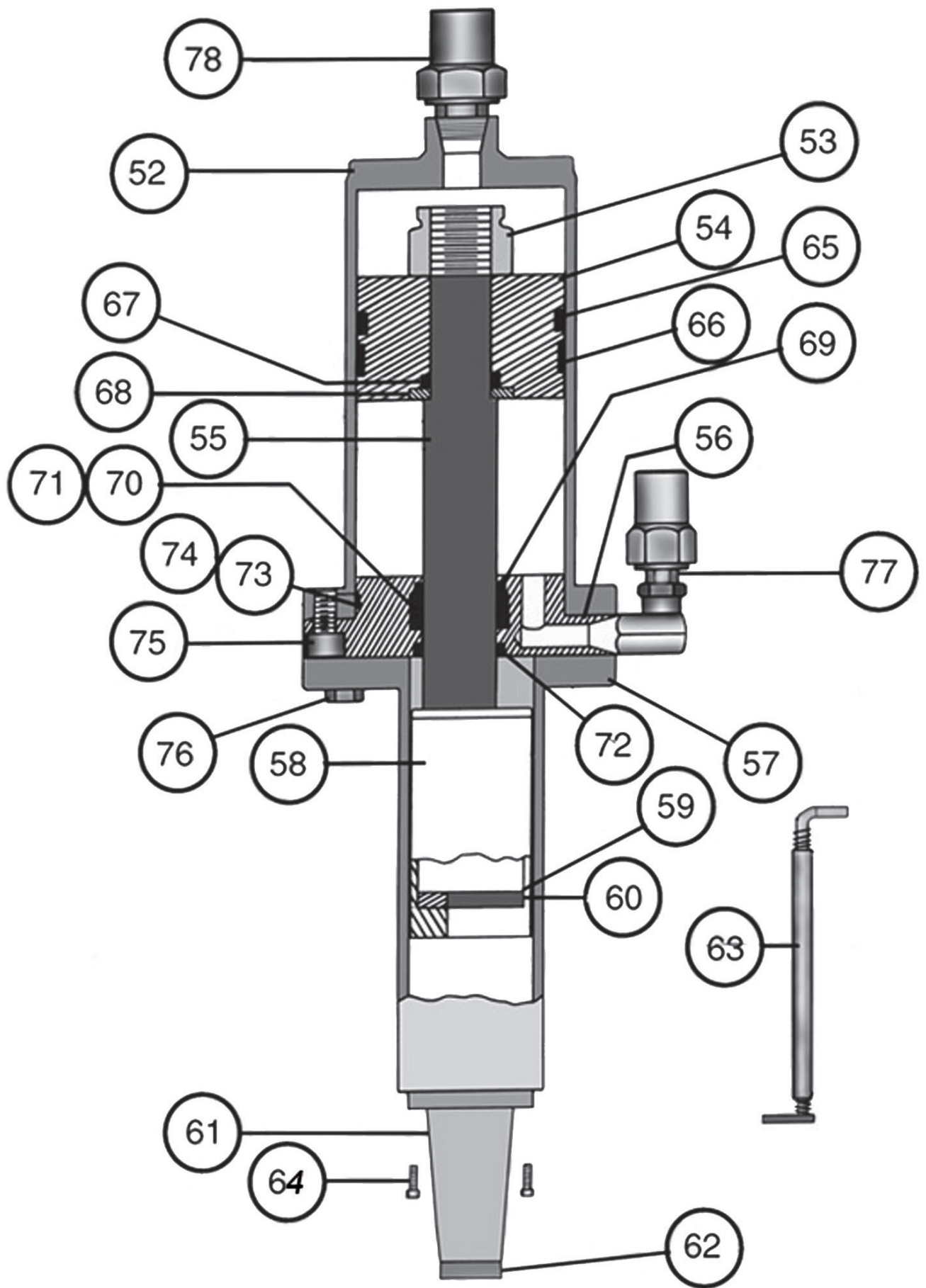

(16)

MODEL C RAM PARTS

KEY	PART#	DESCRIPTION
52	C8052	Cylinder Body
53	C8053	Cylinder Rod Nut
54	C8054	Piston
55	C8055	Cylinder Rod
56	C8056	Cylinder Head
57	C8057	Stanchion
58	C8058	Chuckbox
59	C8059	Retainer Pin
60	C8060	Chuckbox Wear Plate
61	C8061	Tapered Nose Extension
62	C8062	Nose Extension Wear Plate
63	C8063	Latch Assembly
64	C8064	Socket Head Cap Screw
65	C8065	Piston Seal
66	C8066	Wear Ring
67	C8067	"O" Ring
68	C8068	Piston Washer
69	C8069	Snap Ring
70	C8070	Rod Seal
71	C8071	Rod Wiper Bearing
72	C8072	Rod Wiper
73	C8073	"O" Ring #2
74	C8074	Backing Ring
75	C8075	Socket Head Cap Screw 1/2"x1-1/4"
76	C8076	Cap Screw 1/2"x1-3/4"
77	C8077	Hose Swivel (pressure)
78	C8078	Hose Swivel (return)
79	C8079	Seal Kit Contains Parts: 65, 66, 67, 70, 72, 73

NOTE: When ordering please give stroke length or ram.

REBUILDING CYLINDER

Do not disassemble the hydraulic cylinder until you have a new seal kit on hand to ensure cylinder and components are kept clean during the procedure. Refer to page 17 for part numbers.

- (1) Remove both hydraulic hoses from cylinder and plug hoses & ports.
- (2) Wash cylinder to completely remove dirt & grime.
- (3) Cover work bench with clean cloth or paper.
- (4) Remove jacking stanchion from cylinder and set aside.
- (5) Remove cap bolts (75) from cylinder head. Place 3 bolts in tapped holes in a triangular pattern. Evenly pull the 3 bolts so the cylinder head detaches from the cylinder body.
- (6) Pull rod and piston from the cylinder body tube, once the cylinder head is detached, use the cylinder head as a sliding hammer by bumping the chuckbox while pulling the chuckbox. Ensure to sustain the weight of the rod and cylinder to prevent damage. Pull out the rod with attached chuckbox, cylinder & piston.
- (7) Inspect cylinder bore, rod and piston. All **MUST** be free of deep scratches, gouges, and dents as they will cause hydraulic leaks and will ruin your new seals.
- (8) Grip the chuckbox in a vice. Put a wrench on the piston nut. Apply force to which ever one loosens first (piston or chuckbox). Once either the chuckbox or the piston has been removed, slide the cylinder head off the rod.
NOTE: If both piston nut and chuckbox need to be removed, screw two nuts into each threaded end, lock together and unscrew either end. If the chuckbox resists, warm the threaded area evenly to 300 degrees F.
- (9) Remove snap ring (69) and seal from the cylinder head. Change seals and assemble. **NOTE** the orientation of the seals prior to the removal and assembly of new seals. Pry out the wiper ring (70) and insert new wiper ring in the correct orientation. Remove and replace "O" ring and backup (73 & 74).
- (10) Remove piston seal and replace. Be careful not to gouge or scratch the piston. If piston nut does not come off, do not worry about the "O" ring (66) as it does not wear.

- (11) Slide the cylinder head back onto the rod. **NOTE:** If the chuckbox unscrews, the following re-assembly procedure **MUST** be followed.
- (A) Completely clean oil and debris from the rod threads and chuckbox threads with lacquer thinner, then apply Loctite Grade N primer.
 - (B) Coat threads with Loctite 601.
 - (C) Assemble and tighten to 600 ft. lbs.
- (12) Re-assemble cylinder head onto tube. The orientation of the hydraulic fitting should be facing upwards in the same direction as the cylinder head lifting eye. Insert cylinder head onto the tube with bolts and apply force on bolts evenly to seat the head uniformly. Tighten all bolts to 85 ft. lbs.
- (13) Slide stanchion body back on and attach to cylinder head. Tighten bolts up to 110-113 ft. lbs.
- (14) Jack **MUST** be re-calibrated.

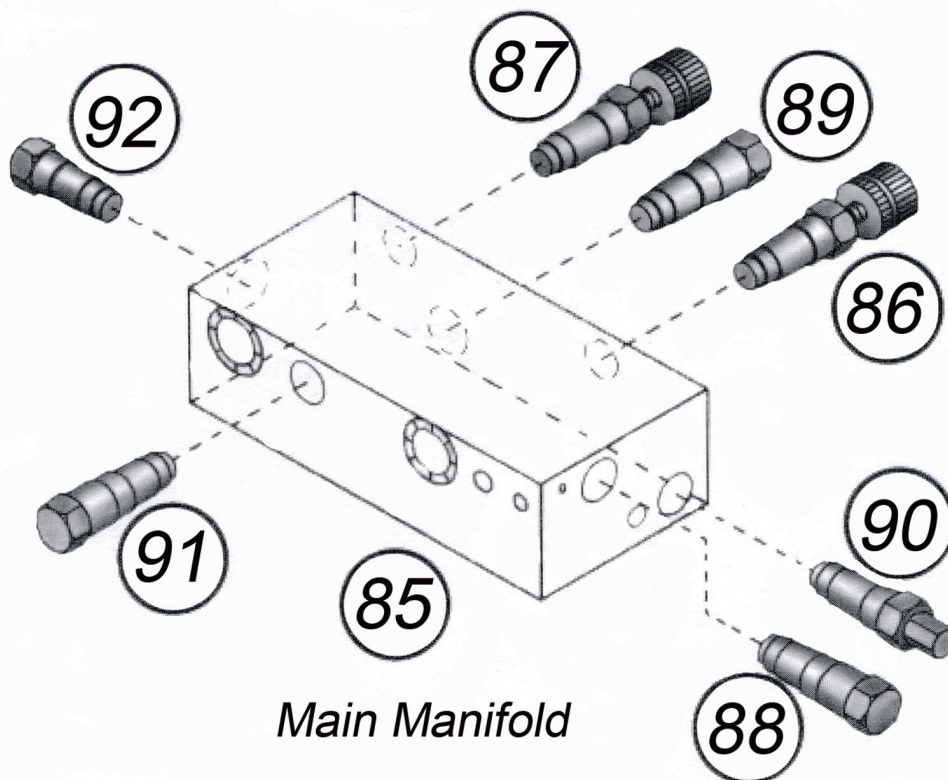
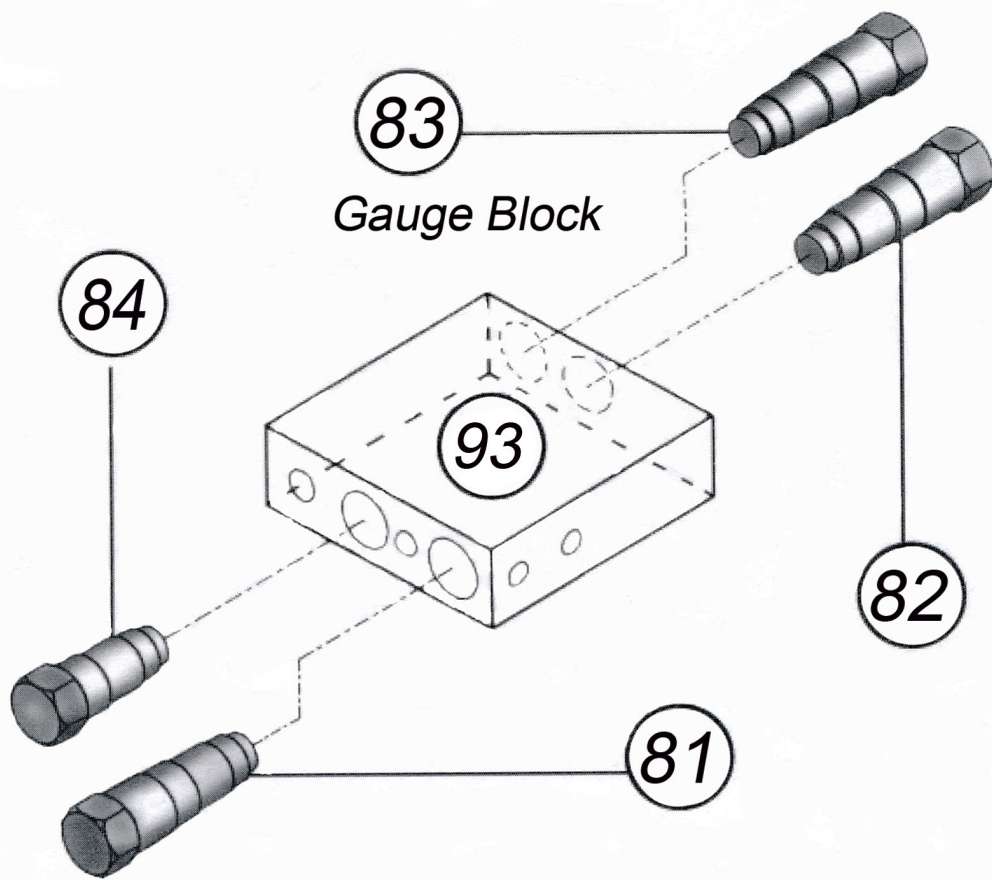

KEY	PART#	DESCRIPTION
81	61400	(CKCB-XAN) P. O. Check Valve
82	61400A	(CKCV-XAN) P. O. Check Valve
83	61400	(CKCB-XAN) P. O. Check Valve
84	61404	(XEOA-XXN) Valve after 2018 (CXCD-XZN) Valve before 2018
85	VB	Main Manifold (No Valves)
85	VBAC	Main Manifold (Complete)
86	61402-L	(RPEC-OEN) Initial Regulator Valve
87	61401-L	(RPEC-OAN) Final Regulator Valve
88	61400-L	(CKCB-XAN) P. O. Check Valve
89	61400-L	(CKCB-XAN) P. O. Check Valve
90	61403	(RPEC-FDN) Relief Valve
91	61405	(LODB-XDN) P. C. Check Valve
92	61404	(CXCD-XZN) Check Valve
93	GB	Gauge Block (No Valves)
93	GBAC	Gauge Block (Complete)

The Hercules stressing system uses Sun hydraulic cartridges (valves) for the system's operation. The valves use external "O" rings to maintain pressure separation between internal chambers in the manifolds if any of the "O" rings become damaged, or worn, hydraulic pressure can bypass causing problematic operation. When inspecting valves, look at the "O" rings for breaks, tears, twists, or deformed surfaces. If there is any debris or dirt lodged in the valve, you may be able to blow it out with an air hose. Valve replacement may be necessary.

When removing a valve always look in the hole to make sure no debris was left inside the manifold.

QUESTIONS & TROUBLESHOOTING

- (1) ***Our jack came without an electric plug on the power cord?***
Your electrician should determine which type of plug will work in your plant. Also, make sure to wire the correct polarity (see question #3).
- (2) ***Unit will not run, or runs and shuts off?***
Check your plant's voltage and amps at the plug. Make sure the jack is set up for the correct voltage and the correct amperage. If the amp and voltage are correct, contact Prestress Supply Inc.
- (3) ***Unit runs but nothing works?***
Check the rotation arrow on the fan housing of the electric motor. If the fan rotation is going the wrong way, have the electrician change the polarity at the electric plug. If the fan is rotating the correct direction, check the coupling between the pump & motor.
- (4) ***Our digital gauge is reading in psi instead of pounds of force?***
The gauge will read in psi until the system is calibrated. Once the calibration is completed, the gauge will switch to pounds of force.
- (5) ***Our units shut off during calibration?***
During the calibration process, the ram is not moving very much so the hydraulic fluid does not circulate and cannot cool down. The eventual heat build up will cause the overload circuit to shut off. So when calibrating, cycle the ram all the way in and all the way out several times. This will move the fluid throughout the system, helping it cool.
- (6) ***Digital gauge will not turn on or gives a low battery warning?***
The digital gauge uses 2 AAA batteries for its backup power. When the jack is turned off, the gauge detects a power loss and switches to battery power. You ***MUST*** turn off the gauge and turn off the stressing unit after use.
When changing the batteries, unscrew the 4 screws on the back of the gauge. Gently remove the back cover plate revealing the battery compartment. ***CAUTION:*** The backplate houses the hydraulic transducer, be very careful when removing and replacing the cover. Do not pinch the wires.

- (7) ***Our analog gauge acts erratic & jumps around?***
Check the snubber valve on the back of the gauge where the hydraulic line comes into the gauge. Close the snubber & open it **SLOWLY** at the same time adding pressure to the system. Once the gauge starts working smoothly, stop opening the snubber. If the snubber is opened too much the gauge will jump around. If the snubber is closed too much the gauge will be slow to respond or not respond at all.
- (8) ***Can we hook up a different brand of ram or pump to the Hercules System?***
NO: Don't do it! Because of the cylinder area of the ram and the operating pressure of the system, trying to make another brand work could be **VERY DANGEROUS!**
- (9) ***Our ram will not move or moves very slowly?***
Check the stanchion area & chuckbox for foreign debris that may have gotten jammed under the chuckbox.
Check internal seals in ram.
Check oil level in tank.
Check oil filter & in tank strainer.
Contact Prestress Supply Inc.
- (10) ***When our jack gets hot, it can no longer pull to the final load?***
Check the psi pressure coming out of the pump by installing a psi gauge capable of 5000 psi inline between the pump & the filter housing. With the jack hot and no cable in the ram, continue to add pressure on the final side until the final regulator is fully open. If the psi gauge does not get to 2800 psi then remove the pump and have it checked.
- (11) ***Our unit will not hold pressure?***
Cap the hoses at the ram and attempt to build & hold pressure. If the unit will now build and hold pressure, replace the internal seals in the ram.
If unit continues to lose pressure, remove and check valve (92 CXCD-XZN).

(12) ***Our unit will not gain pressure?***

First check oil levels in the tank, check filter, in tank strainer, for blockage.

Next plug hoses at the ram and attempt to build pressure.

If pressure now builds up, replace internal seals in ram.

If pressure will not build then check psi pressure coming out of the pump, see question #10.

Check valve (87 RPEC-OAN).

Contact Prestress Supply Inc.

(13) ***Our Unit operates slowly in return?***

Make sure the controls are in return **NOT** in ease-off or initial position.

Check valve (91 LODB-XDN).

Contact Prestress Supply Inc.

(14) ***Hydraulic fluid is visible in the stanchion?***

Check for damage where the cylinder rod goes into the cylinder head. Look for any foreign objects that may have been pushed into the seal area, damaging the seals and possibly the cylinder head and rod.

(15) ***The ease-off function is not working?***

Confirm the controls are in final mode.

Check valve (88 CKCB-XAN).

Contact Prestress Supply Inc.

(16) ***The final pressure continues to build past the target load?***

Check valve (92 CXCD-XZN).

Check valves (88, 89 CKCB-XAN).

Contact Prestress Supply Inc.

(17) ***Our jack is overheating during production?***

Check the pump to see if it is **VERY** hot or pump is making a lot of noise. Remove pump and have it checked. Check oil level, filter element, in tank strainer, for blockage. Run the ram all the way in and all the way out several times allowing hydraulic fluid to circulate and cool.

(18) ***Our gauge pressure lags behind the ram movement?***

Check for trapped air in the line going to the gauge. Check snubber valve settings. See question #7.

THIS PAGE INTENTIONALLY LEFT BLANK

PROVIDING THE WORLD WITH PRODUCTS YOU CAN DEPEND ON

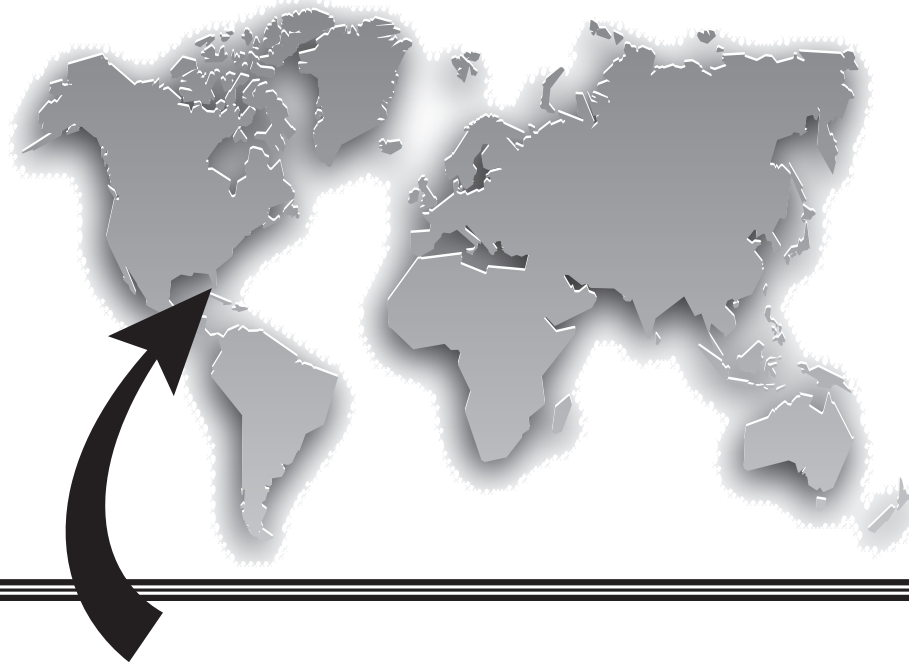

FOR ALL PRESTRESSING/PRECASTING EQUIPMENT

- Single Strand Tensioning Jack
- Super Chucks and Accessories
- Roller Hold downs
- Steam Curing Covers
- Form Release Agent
- Anchors and Inserts
- Bearing Pads, Shims, Chain Guards
- Quality Control - Laboratory
- Wire Ties, Tie Wire
- Concrete Delivery Vehicle
- Load Cell Calibration Equipment



PRESTRESS SUPPLY INC.

Serving the Prestressed Precast Concrete Industry

1355 EAST MAIN STREET • LAKELAND, FLORIDA 33801
PHONE 863-683-4492 OR 863-683-4111 • FAX 863-683-2886
EMAIL sales@psilakeland.com • www.prestresssupply.com